

LOC	DIST	P	F	ZONE	LTR	DESCRIPTION	DATE	APPD
AD	00							
					E	REDRAWN PER 0010-0052-94	2/18/94	HR
					F	REVISED PER 0010-0683-94	9/21/94	HR
					G	REVISED PER 0010-0812-95	9-22-95	PEB
					H	REV PER EC 0320-349-97	27 OCT 97	NS
					J	REV PER EC 063C-233-01	02OCT01	MM

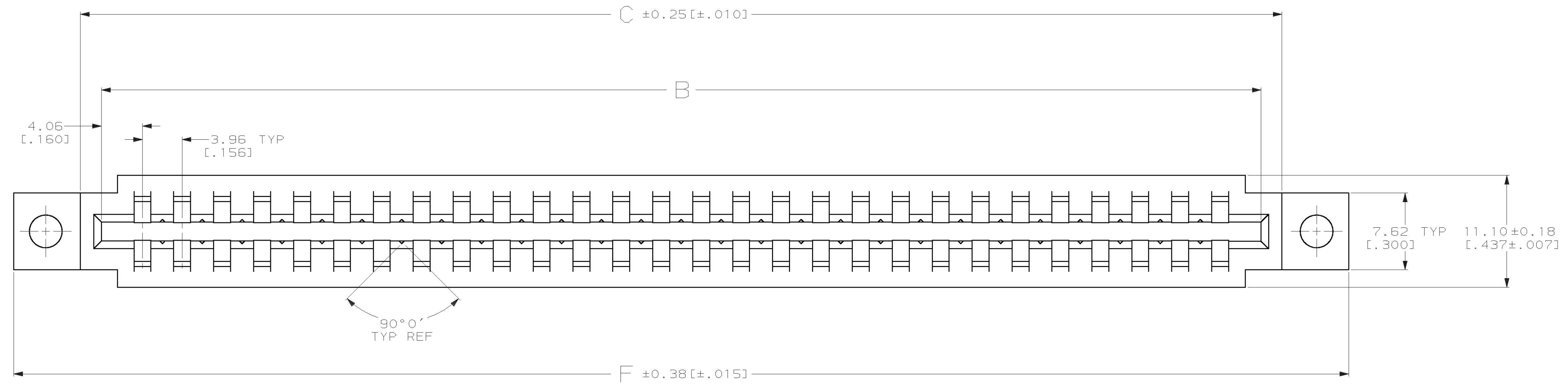

- 1 FIRST 22 POSITIONS MARKED WITH UPPER CASE LETTERS, FOLLOWED BY LOWER CASE LETTERS, FOLLOWED BY UPPERCASE AA, AB, AC ETC. CHARACTERS G, I, O AND Q ARE OMITTED. SEE TABLE FOR END CAVITY IDENTIFICATION.
- 2 PULL GROOVES OPTIONAL THESE LOCATIONS REF ONLY.
- 3 AMP PART NUMBER AND DATE CODE MARKED
- 4 CORING AT AMP'S OPTION REF ONLY.
- 5 OBSOLETE

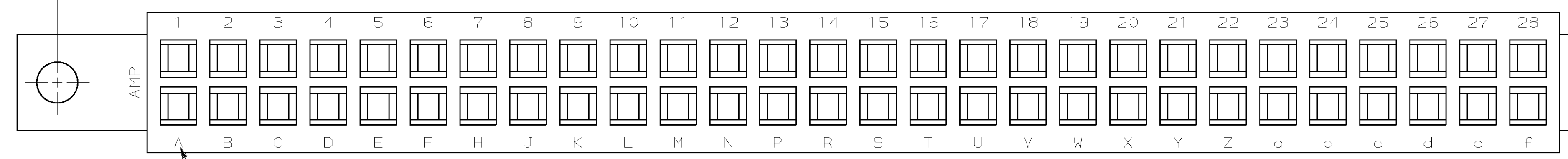
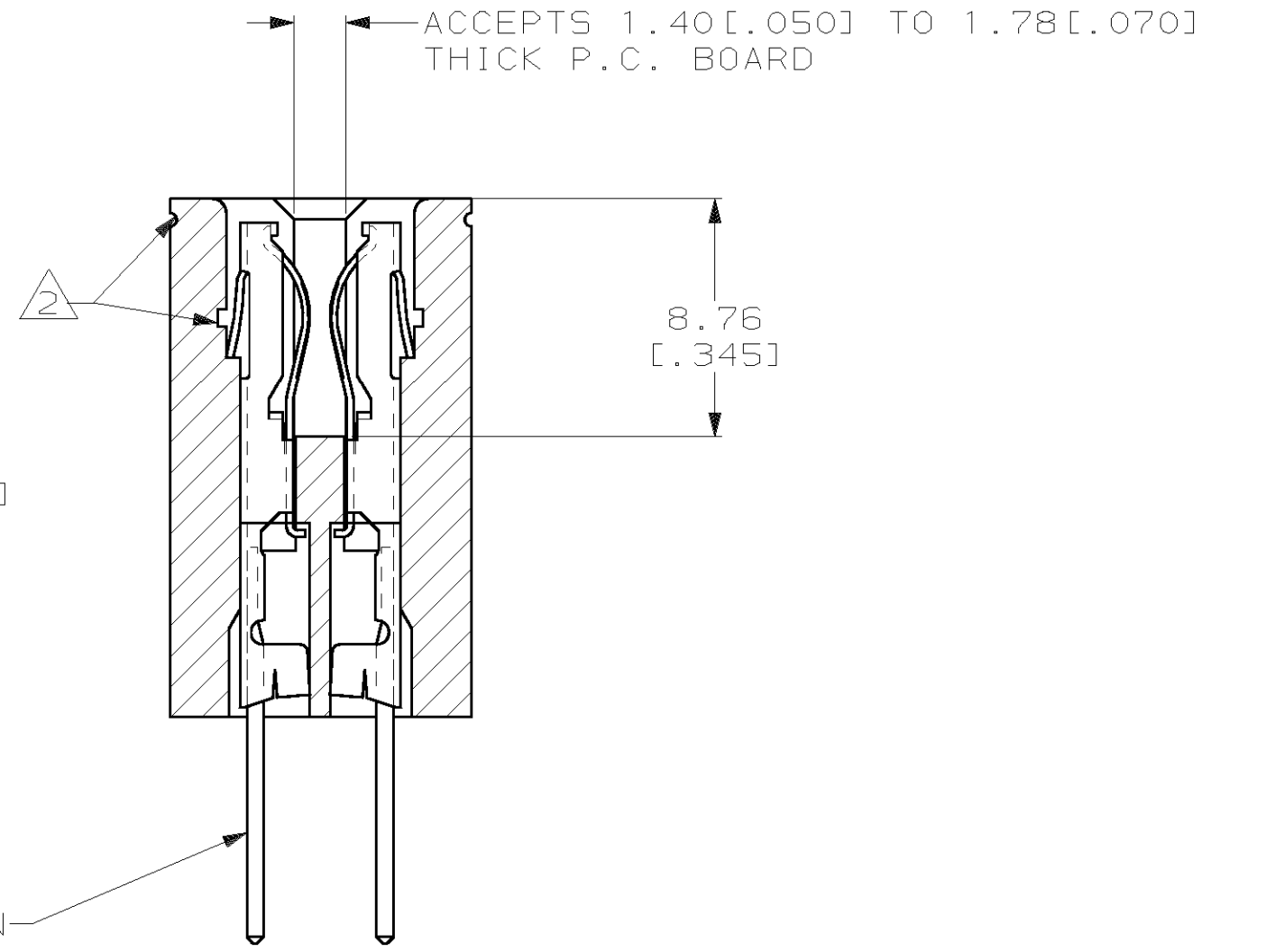
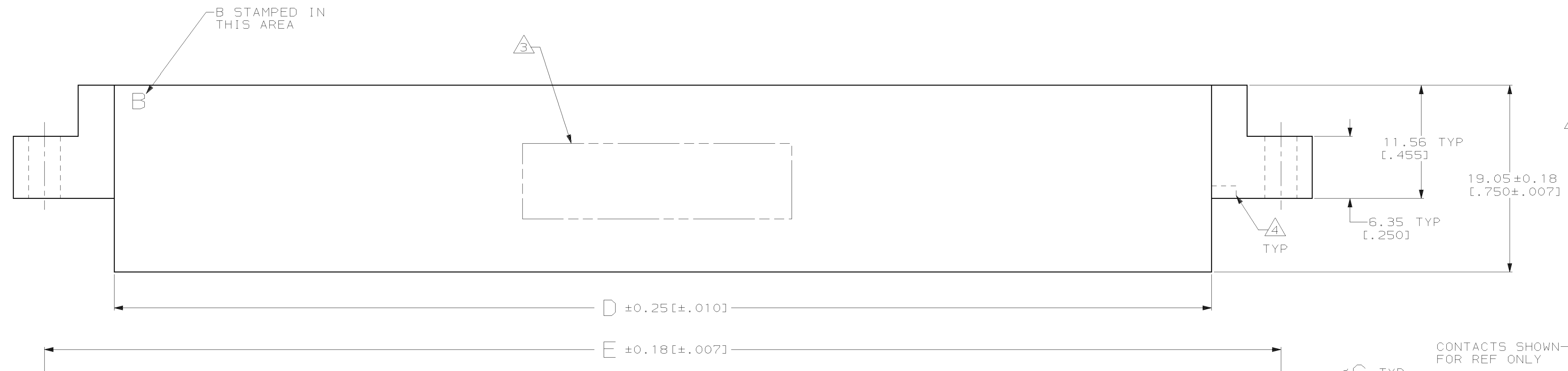

6 & F	3.25 [.128]	45.34 [1.785]	38.99 [1.535]	24.79 [.976]	32.11 [1.264]	27.94 [1.100]	6	531479-3
18 & V	3.25 [.128]	92.89 [3.657]	86.54 [3.407]	72.34 [2.848]	79.65 [3.136]	75.49 [2.972]	18	531479-2
28 & F	3.25 [.128]	132.51 [5.217]	126.16 [4.967]	111.96 [4.408]	119.28 [4.696]	115.11 [4.532]	28	531479-1
END CAVITY IDENT	G	F	E	D	C	B	POSN	PART NUMBER



DO NOT SCALE PRINT. UNLESS SPECIFIED DIMENSIONS IN mm [INCHES] TOLERANCES ON:		DR 12-11-92 J GALLUCCI BG		AMP AMP Incorporated Harrisburg, PA 17105-3508	
2 PLC DEC ± -		CHK 2/18/94 H ROSE		NAME	
3 PLC DEC ± 0.131(.005)		APPD 2/18/94 H ROSE		HOUSING, CRIMP SNAP TWIN LEAF, .156Q	
ANGLES ± -		APPD 2/18/94 M THUMMA		PRODUCT SPEC	
MATERIAL	GLASS FILLED POLYESTER COLOR: BLACK	APPLICATION SPEC		SIZE	D
FINISH	-	WEIGHT	-	CAGE CODE	00779
				DRAWING NO	C-531479
				SCALE	4:1
				SHEET	1 OF 1

THIS DRAWING IS A CONTROLLED DOCUMENT FOR AMP INCORPORATED. IT IS SUBJECT TO CHANGE AND THE CONTROLLING ENGINEERING ORGANIZATION SHOULD BE CONTACTED FOR THE LATEST REVISION.